

V Class



Distinction in Detail





Your yacht is a part of your life. It's a home from home, a space to relax, a gateway to adventure, and a place to spend time with the people who matter most.

A Princess yacht makes the experience unforgettable. Combining breathtaking design, meticulous craftsmanship, cutting-edge technology and exceptional levels of personalisation, our craft set new standards in performance, comfort and style.

Wherever your voyage takes you, you'll remember every moment.



Distinction in Detail

At our shipyards in Plymouth, founded in 1965 on the edge of the English Channel, a highly skilled team of craftspeople come together to create something remarkable.

From designers to engineers, laminators to electricians, carpenters to metalworkers, each one possesses a mastery of their individual craft. And each one is completely focused on the details for which they are responsible.

Because by focusing on every detail, the end result is exactly how we want it to be. By taking pride in every detail, we can be proud of the finished yacht. And by perfecting every detail, we can create the perfect experience.





V Class

Supremely powerful. Exceptionally luxurious. The V Class is a study in contrasts. The deep-V hull translates sheer power into responsive handling to deliver true sporting prowess, while the refined craftsmanship creates the ultimate contemporary and comfortable outdoor lifestyle.

Designed for thrill-seekers everywhere.





V65



Powerful and progressive, the exciting V65 sets a new standard. Her Olesinski-designed deep-V hull is optimised for greater lift and less drag, for lower planning speeds and greater efficiency. When entertaining, her spacious cockpit inspires relaxation with a sunpad and well-equipped dining area leading to the fully equipped aft galley. With engines taking you up to 36 knots, the V65 is as vivacious as she is valiant.





Her flexible saloon can be climate controlled or opened to the elements via triple sliding aft doors and a retractable sunroof. Below deck, eight guests enjoy four beautifully appointed cabins all bathed in natural light from elegant hull glazing, with the option of a further single cabin aft for occasional guests or crew.



V65

Layout and Specifications



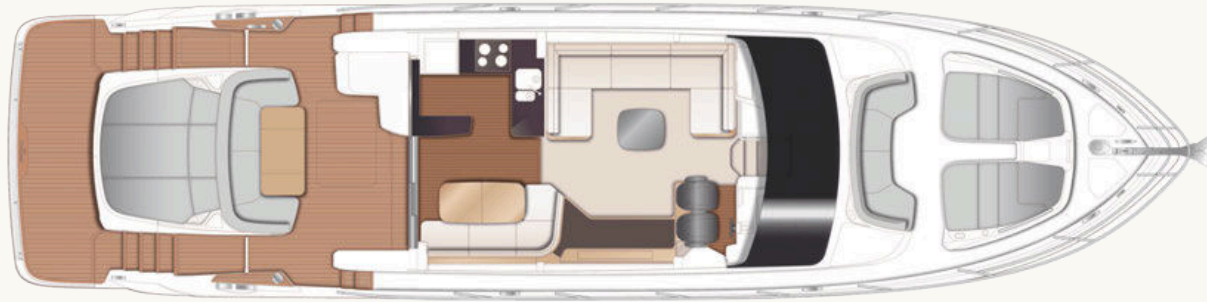

V65 Main Deck

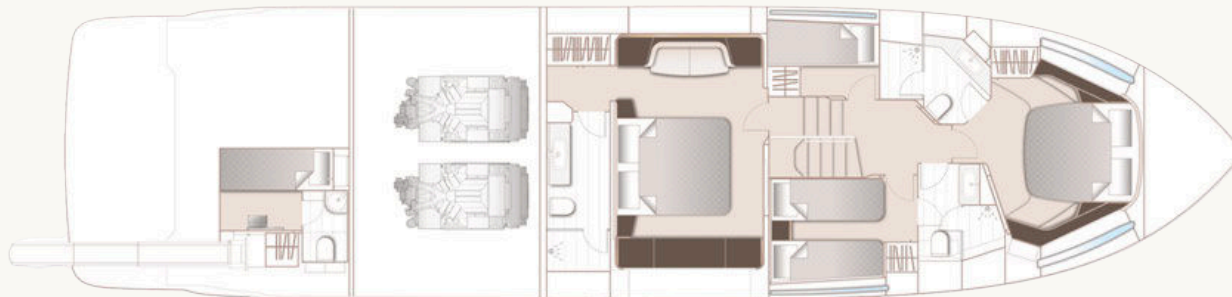

V65 Lower Deck

Principal Dimensions

Length overall (incl. pulpit)	67 ft 7 in / 20.61m
Length overall (excl. pulpit)	65 ft 8 in / 20.03m
Beam	16 ft 7 in / 5.04m
Draft	5 ft 4 in / 1.62m
Displacement approx.	36,477 kg / 80,418 lbs*
Fuel capacity	902 gal / 1,083 US gal / 4,100 l
Water capacity (excl. calorifier)	176 gal / 211 US gal / 800 l
Black water tank	60 gal / 72 US gal / 272 l

Engines - Diesel

Twin MAN V12-1400 (2 x 1,400mhp)	Maximum speed range - 34-36 knots [†]
----------------------------------	--

Full Specification

Deck fittings

- Teak-laid transom platform, cockpit deck and steps to side deck
- Reversible electric anchor winch with foredeck and helm position controls
- Stem head roller with automatic anchor launch and retrieve
- Self-stowing anchor system incorporating one Lewmar Delta anchor (40kg/88lb) with 60m of 9.5mm chain
- Bow rope storage locker
- Deck storage lockers for fenders
- Freshwater deck/anchor wash
- Stainless steel bow fairleads (2) and stern fairleads (2)
- Cast stainless steel bow (2), stern (2) and spring cleats (4)
- Stainless steel round 32mm pulpit and guardrails
- Stainless steel coach roof handrails
- PVC rubbing band with stainless steel insert
- LED deck level lighting
- Illuminated crown logo to transom

- Full set of IMCO navigation lights
- Riding light
- Searchlight with remote control
- Loudhailer (connected to VHF)
- Twin electric horns
- Fuel and water fillers
- Foredeck escape hatch
- Foredeck U-shaped seating area and walk-through
- Foredeck sunbathing area with twin sunbeds including cushions with integrated storage locker and drinks holders (4)

Aft cockpit and bathing platform

- Self-draining
- U-shaped seating/dining area with folding teak table and drinks holders
- Sunbed aft with drinks holders
- Cockpit countertop (aligned with galley countertop and hinging window)
- Port side wetbar featuring bin and sink
- LED overhead and deck level lighting

- Stainless steel handrails
- Life raft stowage locker
- Rope stowage lockers
- Lockable gas strut assisted hatch to lazarette to port side
- Lockable gas strut assisted hatch to lazarette/ optional crew cabin to starboard under aft sunpad
- Lockable gas strut assisted hatch to engine room
- Locker containing remote fuel cocks, manual bilge pump with valve chest and manual controls for automatic fire extinguishers
- Twin transom gates leading to bathing platform
- Transom grab rail
- Ensign socket
- Garage (suitable for up to a Williams SportJet 345 or equivalent) with electro-hydraulic door and tender launch system with electric winch
- Electro-hydraulic raise/lower teak laid bathing platform (500Kg SWL)
- Retractable bathing ladder (manual) in side of hydraulic platform
- Transom steps to access stern from bathing

- platform when in lowered position
- Hot and cold transom shower
- Fusion Signature 6.5" (2) speakers linked to saloon with local control
- 220/240v shore support inlet in locker
- Tonneau canvas cover

Helm position

- Twin helm seats with manual fore and aft adjustment for helmsman, crown logo to both seats, flip up base to helm seat for door access
- Raymarine Axiom XL16 (15.6" display size) multifunction colour display, incorporating GPS/chart plotter, log and echo sounder
- Raymarine Evolution autopilot with P70Rs control head
- 9" multifunction display, displaying engine instrumentation (including fuel levels and fuel flow)
- Single station instruments and controls at Helm Position:
 - power-assisted electro-hydraulic steering
 - adjustable steering wheel
 - rudder position indicator
 - magnetic compass

- electronic engine controls
- trim tab controls with indicators
- bow thruster control
- electric anchor winch remote control
- autopilot
- VHF with DSC R/T with intercom
- remote control searchlight
- horn button
- Storage tray
- Drinks holders
- Toughened glass screen (clear for night vision)
- Windscreen wipers with freshwater windscreen wash
- Exterior black mesh windscreen covers
- Bilge pump controls with visual pump running warnings
- 24v and 240v electrical control panel
- Riding light, helm and navigation light control switches
- USB charging points (2) (1x USB-A and 1x USB-C)
- 220/240v outlet (1)
- LED overhead lighting (24V) and night lighting
- Pantograph helmsman's side door to starboard side deck
- Timber flooring (V-groove planked)

- power-assisted electro-hydraulic steering
- adjustable steering wheel
- rudder position indicator
- magnetic compass
- electronic engine controls
- trim tab controls with indicators
- bow thruster control
- electric anchor winch remote control
- autopilot
- VHF with DSC R/T with intercom
- remote control searchlight
- horn button

Deck saloon

- U-shaped sofa with storage/crockery drawers
- Coffee table
- Electric drop window to port
- Sideboard unit with bottle and glass storage, and refrigerator (Waeco)
- 55" TV on rise and fall
- Fusion Apollo MS-RA770 audio system with Wi-Fi/Bluetooth/ DAB. Paired with Focal 100ICW6 speakers (2)
- Storage drawers below navigator's seat
- Panoramic tinted toughened glass windows port

and starboard

- Manual tension venetian blinds (matte black) to windows
- LED overhead and concealed lighting (24v)
- Access stairway to lower accommodation
- Electric opening roof with skylights with dark grey tint and sliding blinds
- Timber flooring (V-groove planked)
- 220/240v outlets (2)

Dining area

- L-shaped sofa with storage drawer
- Folding dining table/drinks holders (4)
- Stainless steel framed sliding door to cockpit (three pane) with integrated hinging window aft of galley (one fixed pane, two sliding panes, one flip window) and integrated Skysol blind
- Manual tension venetian blinds (matte black) to windows
- LED overhead and concealed lighting (24v)
- 220/240v outlet (2)
- Timber flooring (V-groove planked)

Galley

- Solid Surface countertop
- 4-zone ceramic hob (Bosch)
- Extractor fan
- Combination microwave/convection oven with grill (Bosch)
- Full height fridge/freezer (281l, Beko)
- Twin-bowl (1.5) stainless steel sink with mixer tap
- Slimline full height dishwasher (9 place setting, Bosch)
- Twin waste bin (segmented for recycling)
- Drawers and storage cupboards
- Manual tension venetian blinds (matte black) to windows
- LED overhead and task lighting (24v)
- 220/240v outlets (4)
- Timber flooring (V-groove planked)

Accommodation

- All cabins and bathrooms (exc. crew bathroom) feature opening portholes
- All cabins feature 220/240v power points
- All bathrooms (exc. Crew bathroom) feature 240v shaver points
- All bathrooms feature electric freshwater toilets

Owner's stateroom

- Large double bed with drawers below
- Twin bedside tables
- Walk-through wardrobe area with hanging, drawer storage and full-length mirror
- Dressing table
- Sofa
- Storage drawers
- 50" TV
- Fusion Apollo MS-RA770 audio system with Wi-Fi/Bluetooth/DAB. Paired with Focal 100ICW6 speakers (2)
- Panoramic windows including opening porthole
- Manual tension venetian blinds (grey)
- LED overhead and concealed lighting (24v)
- Individual berth lights
- 220/240v outlets (4) (1 per side and 2 beside vanity unit)
- USB charging points (4) (2 per side (1x USB-A and 1x USB-C))
- Fitted carpet

En-suite bathroom

- Wash basin with thermoformed, Solid Surface

- vanity top
- Mirror to vanity unit
- Storage lockers
- Shower compartment with automatic pump out. Includes overhead rainfall shower and fully adjustable hand shower
- Extractor fan
- Window with opening porthole
- Manual tension venetian blind (grey)
- LED overhead lighting (24v)
- Bathroom accessories
- Solid Surface flooring

Forward stateroom

- Large double bed with drawers below
- Wardrobe with shelves and full-length mirror
- Dressing table
- Storage lockers
- Windows with opening portholes
- Manual tension venetian blind (grey)
- Deck hatch
- LED overhead lighting (24v)
- Individual berth lights
- 220/240v outlets (3) (1 per side and 1 under vanity unit)

- USB charging points (4) (2 per side (1x USB-A and 1x USB-C))
- Fitted carpet

En-suite bathroom

- Wash basin with thermoformed, Solid Surface vanity top
- Mirror
- Storage lockers
- Shower compartment with automatic pump out
- Extractor fan
- Window with opening porthole
- Manual tension venetian blind (grey)
- LED overhead lighting (24v)
- Bathroom accessories
- Solid Surface flooring

Starboard guest cabin

- Two single beds with drawers below (*with option of sliding double bed conversion*)
- Bedside table
- Wardrobe with shelves
- Mirror
- Storage lockers

- Window with opening portholes
- Manual tension venetian blinds (grey)
- LED overhead lighting (24v)
- Individual berth lights
- 220/240v outlets (1)
- USB charging points (2) (1x USB-A and 1x USB-C)
- Fitted carpet

En-suite bathroom

- Wash basin with thermoformed, Solid Surface vanity top
- Mirror
- Storage lockers
- Shower compartment with automatic pump out
- Extractor fan
- Window with opening portholes
- Manual tension venetian blind (grey)
- LED overhead lighting (24v)
- Bathroom accessories
- Solid Surface flooring
- Day access door from lower lobby

Port guest cabin

- Two single beds (bunk)
- Wardrobe with shelf
- Mirror
- Storage lockers
- Window with opening portholes
- Manual tension venetian blinds (grey)
- LED overhead lighting (24v)
- Individual berth lights
- 220/240v outlet (1)
- USB charging points (2) (1x USB-A and 1x USB-C)
- Fitted carpet

Lower lobby / passageway area

- Combination washer/dryer with storage area above located below companionway stairs (Bosch)
- LED overhead and concealed lighting (24v)
- Fitted carpet

Optional crew cabin (in place of aft lazarette)

- Furniture in specified choice of boat timber
- Single bed with storage below
- Lockers with shelf

- Opening porthole
- Hinged door with access from hatch under aft sunpad
- LED overhead lighting (24v)
- Individual berth lights
- 220/240v outlet (1)
- USB charging point (2) (1x USB-A and 1x USB-C)
- Timber flooring (V-groove planked)

En-suite bathroom

- Bathroom in white laminate
- Wash basin with Solid Surface vanity top
- Mirror
- Storage lockers
- Shower with automatic pump out
- Extractor fan
- LED overhead lighting (24v)
- Bathroom accessories
- Non-slip flooring (GRP)

Power and drive systems

- Propeller shafts in Marinemet
- 5-bladed propellers in nickel aluminium bronze
- Bow thruster (170kgF) with dual-station controls

- High speed balanced rudders
- Power-assisted electro-hydraulic steering system
- Trim tabs with indicators
- Cathodic protection for stern gear
- Stern gear, engines, fuel tank fillers, etc all electrically bonded
- Forward and aft engine room bulkheads and engine room headlining to be integrally bonded including insulation with acoustafoam layers
- High volume air intakes
- Engine room extractor fan with electronic time delay
- Engine exhaust silencers and water-cooled exhausts
- Engine beds integrally moulded with hull for strength and vibration absorption
- Engines flexibly mounted
- Automatic fire extinguisher with remote override control
- Automatic and manual bilge pumps
- Engine room lighting
- Engine room access from cockpit deck, via hatch with ladder
- Electronic engine and gear shift controls
- Fresh water supply point in engine room
- Dripless self-aligning shaft seals

Electrical systems

24 Volt:

- 4 x heavy duty batteries for engine starting
- 4 x heavy duty auxiliary batteries
- 1 x generator battery
- Battery link facility with remote control at helm position
- Battery banks are charged using a voltage sensitive relay that parallels both battery banks when a charging source is present
- 60-amp battery charger charges both banks of batteries via an automatic switch charging system
- 6-amp battery charger for generator battery
- Remote battery master switches with control switch at main switch panel
- Circuit breakers on all circuits
- 12v voltage dropper for certain navigation and radio circuits

220/240 Volt:

- EU specification: 11kW diesel generator in own sound shield with water cooled specially silenced

exhaust systems

- US specification: 13.5kW diesel generator in own sound shield with water cooled specially silenced exhaust systems
- Automatic fire extinguisher situated by generator
- 60-amp shore support inlet
- 6-amp battery charger for generator battery
- Generator/shore support change-over switch
- Polarity check system
- Earth leakage safety trip
- Circuit breakers on all circuits
- Power points in: master stateroom, guest cabins, galley and saloon area
- Shaver points in all bathrooms (exc. crew)

Fuel system

- Twin fuel tanks (in NS8 marine grade alloy) with interconnection system giving 902 gal / 1083 US gal / 4,100 l capacity
- Fuel fillers on port and starboard side decks
- High-capacity duplex fuel filters with water traps with change-over valves, water warning sensors connected to warning lights at lower helm
- Remote fuel cocks in cockpit locker

- Fuel gauges at main helm console (via MFD)

Water system

- Water tanks totalling 176 gal / 211 US gal / 800 l plus 16 gal / 19 US gal / 73 litres hot water calorifier
- Water heated by engines and 240v immersion heater
- Automatic water pump with filter
- Main circuit breaker at switch panel
- Water level gauge
- Deck filler
- Electric WC system with 60 gal / 72 US gal / 272 l holding tank, content gauge and low noise electric overboard discharge, with macerator backup system as well as dockside discharge system

Bilge pumps

- Automatic/manual override electric bilge pumps in engine room (2), rudder area, lazarette and forward accommodation (6 in all)
- High-capacity manual bilge pump with valve system and suction points in same areas

- Electric bilge pumps have controls and warning lights at main helm

Fire extinguishers

- Automatic/manual override fire extinguishers in engine room with warning system at helm position
- Hand-operated fire extinguishers (6) in master stateroom, forward, port and starboard guest cabins, galley and helm position
- Additional extinguisher fitted when optional aft cabin is specified
- Automatic under helm fire extinguisher at lower helm

Other standard equipment

- Ensign staff
- Fenders (6)
- Mooring warps (4)
- Boat hook
- First Aid kit
- Tool kit
- Owner's manual and engine manual
- Functional bed linen supplied to all cabins

(including optional aft cabin when specified)

- Set of glassware (8 settings consisting of tumbler and wine glasses)
- Set of Princess china (8 settings consisting of plate, side plate, bowl, cup & saucer)
- Ship's document case
- Anchor winch back up handle
- V65 canopy badges

Finishes

- Teak-laid decks to transom platform, steps to cockpit, and steps to side decks
- Timber-laid floor to galley, deck saloon and dining area (V-groove planked)
- Furniture in Rovere oak with satin finish as standard. Optional finishes include Silver oak satin finish, Ash satin finish or Walnut wood in a satin or gloss finish
- Solid Surface floors in all bathroom suites in guest accommodation
- Solid surface wash hand basin vanity tops in all bathroom suites in guest accommodation
- Galley countertop in Solid Surface
- Choice of high-quality carpet and upholstery fabric from extensive range

- Exterior upholstery in white vinyl as standard, with optional upgrade to Comfort Exterior available
- Manual tension venetian blinds (matte black to main deck, grey to lower deck) to all windows
- Optional crew cabin furniture in specified choice of boat timber with timber flooring. Crew bathroom in white laminate with white Solid Surface vanity tops and non-slip (GRP) flooring.



V55



The striking all-new V55 features a sleek and dynamic exterior profile coupled with an intelligent use of space and all the exceptional performance qualities synonymous with our V Class range. Her main deck has been purposely designed for those who enjoy true open-boating. The expansive cockpit features a large L-shaped seating area with additional seating aft around a substantial folding teak table served by a wetbar opposite with electric barbecue. This area connects to the saloon via a drop down sliding door and opening window aft of the galley, seamlessly integrating the two living areas as required. Her main deck also boasts a large sunpad located aft of the cockpit and a further foredeck seating and sunbathing area. With a top speed of 37 knots, she promises to deliver a powerful V Class sports yacht experience.





This new V Class continues to deliver throughout her lower deck with optimum use of space and multiple accommodation options. Featuring three generous guests cabins, she is class leading for a yacht of her size. Her ensuite master stateroom utilises the full beam of the yacht. Additional guests can enjoy the ensuite forward cabin which benefits from the option of scissor berths in addition to a third bunk cabin. There is also the option of a single aft cabin for crew or occasional guests.





Experience the V55



Take a virtual tour of the V55



V55

Layout and Specifications





V55 Main Deck

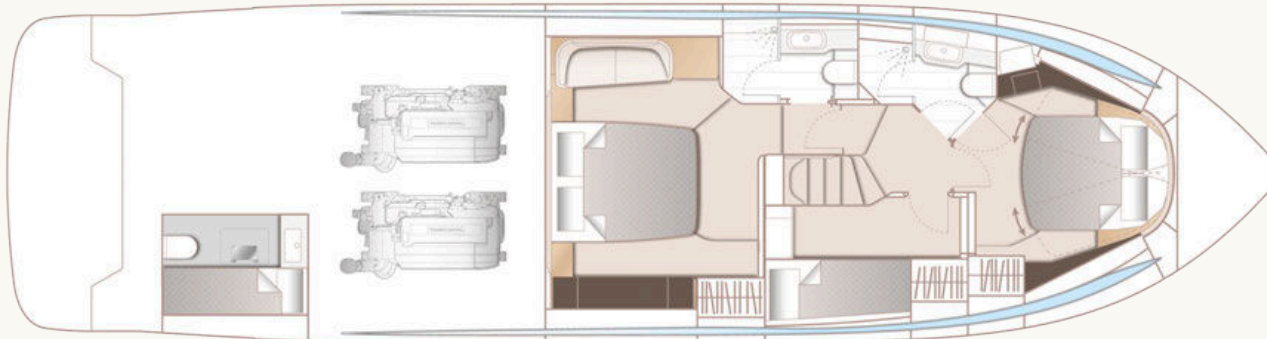

V55 Lower Deck

Principal Dimensions

Length overall (incl. pulpit)	58 ft 5 in / 17.81m
Length overall (excl. pulpit)	56 ft 9 in / 17.29m
Beam	15 ft 3 in / 4.65m
Draft	4 ft 9 in / 1.44m
Displacement approx.	28,589 kg / 63,028 lbs*
Fuel capacity	550 gal / 660 US gal / 2,500 l
Water capacity (excl. calorifier)	103 gal / 123 US gal / 466 l
Black water tank	66 gal / 79 US gal / 300 l

Engines - Diesel

Twin Volvo D13-1000 (2 x 1,000mhp)	Maximum speed range - 33-35 knots†
------------------------------------	------------------------------------

Detailed Specification

Deck fittings

- Teak-laid transom platform, cockpit deck and steps to side deck
- Reversible electric anchor winch with foredeck and helm position controls
- Stemhead roller with automatic anchor launch and retrieve
- Self-stowing (32kg/70lb) Delta anchor with 40m of chain (9.5mm)
- Bow rope storage locker
- Freshwater deck/anchor wash
- Walk through coachroof seating area
- Deck storage locker for fenders
- Princess stainless steel bow, stern and spring cleats (8)
- Stainless steel pulpit and guardrails
- Stainless steel coachroof handrails
- Foredeck hatch
- PVC rubbing band with stainless steel insert
- LED deck level lighting
- Illuminated crown logo to transom
- Full set of IMCO navigation lights

- Riding light
- Searchlight with remote control
- Twin electric horns
- Fuel and water fillers
- V55 badges, 1 per side, aft canopy

Cockpit and bathing platform

- Patio door with lift up section to starboard with locking gas strut. Moving panel slides to port and retracts forming large open section.
- Self-draining
- L-shaped seating/dining area, folding teak table with cushion infill to extend seating into U-shaped configuration
- Aft sunbed
- Wetbar with barbecue, drawer fridge and storage
- LED overhead and deck level lighting
- Hand holds moulded into GRP inboard faces of the aft buttresses.
- Garage(to take tender up to 3.45m) with electro-hydraulic door and tender launch system with

- electric winch
- Liferaft stowage locker
- Lockable gas strut assisted hatch to port lazarette
- Lockable gas strut assisted hatch to lazarette/ optional crew cabin
- Lockable gas strut assisted hatch to engine room
- Locker containing remote fuel cocks, manual bilge pump with valve chest and manual controls for automatic fire extinguishers
- Twin transom gates leading to bathing platform
- Electro-hydraulic raise/lower teak laid bathing platform (450Kg SWL)
- Retractable bathing ladder (manual) in side of hydraulic platform
- Transom steps to access stern from bathing platform when in lowered position
- Hot and cold transom shower
- Fusion Signature 6.5" speakers waterproof speakers (2) linked to saloon sound system
- with local control (Fusion Apollo ERX-400) (additional x 2 speakers - optional)
- 220/240v shore support inlet in locker

- Tonneau cover

Helm position

- Twin helm seats with fore and aft adjustment for helmsman
- Instrument console with 10" colour mfd screen incorporating engine instrumentation and fuel gauges and rudder indicator
- 16" brilliant colour mfd incorporating GPS/chartplotter, log and echo sounder
- Instruments and controls at Helm Position:
 - power-assisted electro-hydraulic steering
 - adjustable steering wheel (new style Isotta steering wheel)
 - rudder position indicator
 - high-speed magnetic compass
 - electronic engine controls and joystick control
 - trim tab controls with indicators
 - bow thruster control
 - electric anchor winch remote control
 - autopilot
 - VHF with DSC R/T with intercom
 - remote control searchlight
 - horn button
- Drinks holders

- Toughened glass screen (clear for night vision)
- Windscreen wipers with freshwater windscreen wash
- Black mesh sunscreens
- Bilge pump controls with visual pump running warnings
- 24v and 240v electrical control panel
- Riding light, helm and navigation light control switches
- USB connection point
- LED overhead lighting (24v) and night lighting
- Electric drop window to starboard side
- Timber flooring (V groove planked)

Saloon

- U-shaped sofa with crockery storage below
- Folding dining table or coffee table with integrated storage
- 50" UHD LED TV on rise and fall with Sony BDP-S3700 Blu-Ray player
- Fusion Apollo MS-RA770 audio system paired with Focal 100 ICW6 speakers (2)
- Blinds or sunscreens to all windows and doors
- Dimmable LED overhead and concealed lighting (24v)

- Access stairway to lower accommodation
- Electric opening roof with integrated blinds
- Timber flooring (V groove planked)

Galley

- Sylmar white (satin finish) solid surface worktop
- Ceramic 4-zone hob (De Dietrich hob, white)
- Hob extractor
- Under-counter fridge freezer
- Combination microwave/convection oven with grill
- Stainless steel sink with mixer tap
- Waste bin
- Drawers and storage cupboards in taupe grey soft touch finish
- Stainless steel framed drop down patio door to cockpit with hinge up window over wetbar
- Blinds to all windows and doors
- Dimmable LED overhead and task lighting (24v)
- 220/240v outlets (4)
- Timber flooring (V groove planked)

Accommodation

- All cabins and bathrooms feature opening

portholes

- All cabins feature 220/240v power points
- All bathrooms feature electric freshwater toilets and 240v shaver points

Owner's stateroom

- Large double bed
- Twin bedside tables
- Wardrobe with hanging and shelf storage
- Mirror
- 2-seater sofa to port
- Storage lockers and drawers
- Sideboard unit to starboard with storage lockers and drawers and integrated dressing table
- 43" UHD LED TV
- Audio system with Apollo RA-670 with DAB and external USB, Sony BDP-S3700 Blu-ray player. Paired with Focal 100 ICW6 speakers (2)
- Panoramic windows including opening porthole with venetian blinds
- Dimmable LED overhead and concealed lighting (24v)
- Individual berth lights
- 220/240v outlets (2)
- Double USB charging points (2)

- Fitted carpet

En-suite bathroom

- Wash basin and worktop in thermoformed solid surface in Sylmar White (satin finish)
- Mirror
- Storage lockers
- Shower compartment with automatic pump out
- Extractor fan
- Windows with opening portholes and venetian blind
- LED overhead and concealed lighting (24v)
- Bathroom accessories
- Flooring in Koko White (satin finish) solid surface

Forward stateroom

- Large double bed with option of scissor berths
- Wardrobe with shelves
- Dressing table
- Mirror
- Storage lockers
- Window with opening porthole and venetian blind
- Deck hatch

- LED overhead and concealed lighting (24v)
- Individual berth lights
- 220/240v outlets (2)
- Double USB charging points (2)
- Fitted carpet

En-suite bathroom

- Wash basin and worktop in thermoformed solid surface in Sylmar White (satin finish)
- Mirror
- Storage lockers
- Shower compartment with automatic pump out
- Extractor fan
- Window with opening porthole and venetian blind
- LED overhead and concealed lighting (24v)
- Bathroom accessories
- Flooring in Koko White (satin finish) solid surface

Starboard guest cabin

- Two single bunk beds with drawers below
- Wardrobe with shelves
- Mirror
- Storage lockers with shelves

- Window with opening portholes and venetian blind
- LED overhead and concealed lighting (24v)
- Individual berth lights
- 220/240v outlets (1)
- Double USB charging points (2)
- Fitted carpet

Optional crew cabin (in place of aft lazarette)

- Single bed with storage below
- Storage locker
- Opening porthole
- LED overhead lighting (24v)
- Individual berth light
- 220/240v outlet (1)
- Non-slip safety flooring
- Mirror
- Washbasin with solid surface worktop
- Electric freshwater toilet
- Bathroom accessories

Power and drive systems

- 5-bladed propellers in nickel aluminium bronze
- Bow thruster (210kgf/463lbf) with controls

- Engine room lighting
- Engine room access hatch and ladder
- Volvo electric power assisted steering “joystick ready” as standard
- Trim tabs with indicators
- Electronic engine and gear shift controls
- Engine room extractor fan with electronic time delay
- Fresh water supply point in engine room
- Dripless self-aligning shaft seals

Electrical systems

24 Volt:

- 4 x heavy duty batteries for engine starting
- 4 x heavy duty auxiliary batteries
- Battery link facility with remote control at helm position
- Both battery banks are charged using a voltage sensitive relay that parallels both battery banks when a charging source is present
- 60 amp battery charger charges both banks of batteries via an automatic switch charging system
- Remote battery master switches with control

- switch at main switch panel
- Circuit breakers on all circuits
- 12v voltage dropper for certain navigation and radio circuits
- Princess Connect Telemetry and maintenance

220/240 Volt:

- 9.5Kw diesel generator in own sound shield with water cooled specially silenced exhaust
- Automatic fire extinguisher
- 50 amp shore support inlet
- Generator/shore support change-over switch
- Polarity check system
- Earth leakage safety trip
- Circuit breakers on all circuits
- Power points in: Owner’s stateroom, guest cabins, galley and saloon area
- Shaver points in all bathrooms

Fuel system

- Twin fuel tanks (in NS8 marine grade alloy) with interconnection system giving 484 gal / 581 US gal / 2,200l
- Fuel fillers on port and starboard side decks

- High-capacity duplex fuel filters with water traps with change-over valves, water warning sensors connected to warning lights at helm
- Remote fuel cocks in cockpit locker
- Fuel gauges at helm console

Water system

- Water tanks totalling 105 gal / 126 US gal / 477l plus 16 gallons/19 US gal / 73l / hot water calorifier
- Water heated by engines and 240v immersion heater
- Automatic water pump with filter
- Main circuit breaker at switch panel
- Water level gauge
- Deck filler
- Electric freshwater toilet system with 66 gal / 79 US gal / 300l holding tank, content gauge and low noise manual overboard discharge with dockside discharge system

Fire extinguishers

- Automatic/manual override fire extinguisher in engine room with warning system at helm

position

- Hand-operated fire extinguishers (5) in owner's stateroom, forward and starboard guest cabins, galley and helm position
- Additional extinguisher fitted when optional aft cabin is specified

Bilge pumps

- Automatic/manual override electric bilge pumps in engine room (2), rudder area, lazarette and forward accommodation (6 in all)
- High-capacity manual bilge pump with valve system and suction points in same areas
- Electric bilge pumps have controls and warning lights at helm and warning light with audible alarm at helm

Other standard equipment

- Ensign staff
- Fenders (6)
- Mooring warps (4)
- Boat hook
- First Aid kit
- Tool kit

- Owner's manual and engine manual
- Quilted bedspreads supplied to all cabins (except optional crew cabin)
- Anchor winch back up handle
- Storage locker in lower lobby

Finishes

- Teak-laid decks to transom platform, cockpit deck and steps to side decks
- Timber flooring (V groove planked) to galley, saloon and helm
- Furniture in Rovere oak with satin finish as standard. Optional finishes include ash or silver oak with a satin finish or walnut wood in a satin or gloss finish
- Upper accommodation furniture with finish and materials to complement the exterior living spaces
- Solid surface floors, counter tops and sinks in all bathrooms
- Galley worktop in solid surface
- Choice of high-quality carpet and upholstery fabric from extensive range
- Blinds or sunscreens to all windows and

portholes

- Optional crew cabin has non slip safety flooring,
crew bathroom has white solid surface
countertops



V50



The all-new V50 is installed with premium technology to provide an ease of ownership which makes boating more accessible to new owners. An intuitive IPS system and joystick allows for easy piloting, whilst the addition of the fully integrated Volvo Penta assisted docking system can assist in the management of external factors such as wind, current and manoeuvring in crowded marinas. Additional technology includes premium audio from Naim; plus the new Garmin On-Deck smart boat system, an integrated remote connectivity solution which tracks, monitors and controls selected on-board systems from virtually anywhere via a smartphone app.









When entertaining, the extended cockpit provides exceptional outdoor living space in which to create unforgettable experiences. The elongated canopy provides a shaded area to escape the heat of the sun whilst being in a position to fully appreciate the yacht's balanced performance.

Below deck, a bright, modern open galley sits opposite a sociable entertaining space. Four guests enjoy two beautifully appointed cabins that are filled with natural light from the extensive hull glazing, with a full-beam master stateroom situated amidships. The forward en-suite has additional access to the saloon for use as a day head when required.



Take a virtual tour of the V50 Deck Saloon



Take a virtual tour of the V50 Open





V50

Layout and Specifications

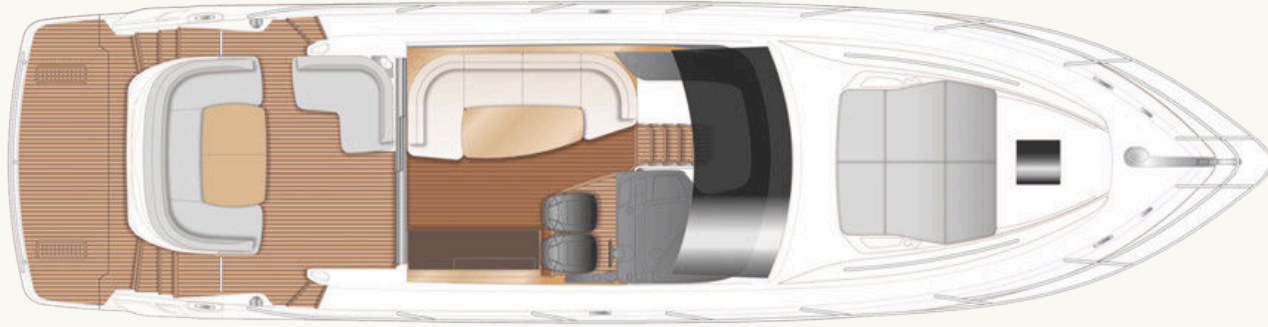

V50 Main Deck



V50 Lower Deck

Principal Dimensions

Length overall (incl. pulpit)	52 ft 7 in / 16.02m
Length overall (excl. pulpit)	50 ft 4 in / 15.35m
Beam	13 ft 4 in / 4.08m
Draft	3 ft 7 in / 1.09m
Displacement approx.	18,234 kg / 40,199 lbs*
Fuel capacity	341 gal / 410 US gal / 1,550 l
Water capacity (excl. calorifier)	76 gal / 91 US gal / 345 l
Black water tank	37 gal / 44 US gal / 170 l

Engines - Diesel

Twin Volvo IPS 650 (2 x 480mhp) Maximum speed range - 29-31 knots†

Full Specification

Deck fittings

- 6mm Teak-laid transom platform, transom steps, cockpit deck and steps to side deck
- Lewmar reversible electric anchor winch with foredeck and helm position controls
- Self-stowing anchor system incorporating one 20kg/44lb Lewmar Delta galvanised steel anchor with flush pin shackle fitted and 40m galvanised 9.5mm chain
- Stemhead roller with automatic anchor launch and retrieve
- Stainless steel bow, stern and spring cleats
- Stainless steel bow fairleads
- Stainless steel pulpit and guardrails
- Stainless steel coach roof handrails
- PVC rubbing band with stainless steel insert
- Illuminated crown logo to transom
- Full set of IMCO navigation lights
- Riding light
- Remote control searchlight
- Single electric horn
- Fuel and water fillers

- Holding tank dockside discharge connection
- Deck hatch access to chain locker with fender stowage rack
- Foredeck escape hatch
- Foredeck drinks holders (4)
- Ensign socket

Cockpit and bathing platform

- Self-draining
- Upholstered aft U-shaped
- Forward L-shaped seating/dining area (optional seat infill)
- Cup holders to L-shaped seating (2)
- Folding teak dining table
- LED overhead and low deck level lighting
- Cockpit cover
- Stainless steel handrails
- Lockable transom hatch to stern lazarette with gas strut assistance
- Lockable access hatch to engine room
- 220/240v shore support inlet in locker
- Life raft stowage locker

- Transom bathing platform with integrated foldaway swimming ladder (with optional electro-hydraulic raise/lower mechanism - note when this option is selected it includes transom steps to access stern from bathing platform when in lowered position)
- Port and starboard transom gates leading to bathing platform
- Hot and cold transom shower
- Storage lockers
- Waterproof speakers linked to saloon sound system
- Fender stowage rack in engine room/lazarette
- Seat locker containing remote fuel cocks, manual bilge pump with valve chest and manual controls for automatic fire extinguisher

Helm

- Twin upholstered seats, manually adjustable helm seat (fore/aft), fixed position navigator
- Instrument console incorporating engine instruments and fuel gauges

- Instruments and controls at helm position include:
 - Power-assisted electric steering system
 - Adjustable steering wheel
 - High speed magnetic compass
 - Electronic engine controls with integrated trim control
 - Joystick manoeuvring control
 - Electric anchor winch with remote control
 - Volvo/Garmin 16" MFD, incorporating GPS chart plotter, engine instrumentation, alarm warning system, autopilot control, fuel gauges, speed and distance log, echo sounder and steering angle indicator
 - VHF with DSC R/T with intercom
 - Single remote-control searchlight
 - Horn button to operate single electric horn
- Twin windscreen wipers
- Windscreen freshwater pressure wash
- Bilge pump controls with audible and visual alarm for bilge pumps (3)
- Electric drop window to starboard side
- Engine room fire extinguisher warning system
- Drinks holder (2) at console, with additional drink holder (1) at base of navigator seat
- Toughened un-tinted glass screen

- Black mesh sunscreens for exterior use
- USB charging points
- Riding light, helm and nav light control switches
- Timber-laid flooring

Deck saloon

- U-shaped sofa with drawers
- Dining table
- Sideboard
- Refrigerator
- Curtains, blinds or sunscreens to all windows and doors
- LED overhead downlighters
- Access stairway to lower accommodation
- Electric opening roof
- Triple stainless steel framed sliding doors to cockpit
- Fusion Apollo MS-RA670 audio unit (with external USB connection) with Wi-Fi and Bluetooth connected to saloon Fusion 6" CL602 speakers (2) and cockpit speakers
- Timber flooring
- 220/240v outlets (2)
- USB charging points (2)

Lower saloon

- U-shaped sofa with single drawer and top loading storage (top loading storage is occupied by air conditioning unit when option is specified)
- Table
- Storage lockers
- LED overhead downlighters
- 24/240v main electrical control panel with battery isolation switches
- Fusion Apollo MS-RA670 audio unit (with external USB connection) with Fusion 6" CL602 speakers (2)
- Window with opening portlight (1)
- Manual tension venetian blinds
- Thermal heat alarm
- 220/240v outlets (1)
- USB charging points (2)

Galley

- Sylmar white solid surface worktop
- 2-zone ceramic hob
- Sylmar white solid surface sink with Monobloc mixer tap (remains white for all options)
- Combination microwave/oven with grill

- Full height fridge freezer (270l), with deep freeze drawers
- Waste bin
- High/low storage cupboards, drawers and lockers
- Timber-laid flooring
- Window with opening portlight
- Manual tension venetian blind
- Hob extractor fan
- Cutlery and crockery storage
- Chopping board
- 220/240v power outlets (4)
- LED overhead task lighting (24v), concealed light and night lighting
- Storage bin under galley sole

Accommodation

- All cabins and bathrooms feature opening portholes
- All cabins feature 220/240v power points
- All bathrooms feature electric freshwater toilets and 240v shaver points

Owner's stateroom

- Large double bed with bedside tables and drawers below
- Wardrobe with shelves and full-length mirror
- Drawers and storage lockers
- Sideboard
- LED overhead and individual berth lights (24v)
- Starboard side sofa
- Panoramic windows in toughened glass with opening ports
- Manual tension venetian blinds
- Fitted carpet
- 220/240v outlets (2)
- USB charging points (4)

En-suite bathroom

- Solid surface worktop
- Wash basin with Monobloc mixer tap
- Separate stall shower with extractor fan and auto pump out
- Mirror
- LED overhead and concealed lighting (24v)
- Storage locker
- Window with opening portlight
- Manual tension venetian blinds
- Solid surface flooring

- Bathroom accessories
- 220/240v shaver socket

Forward stateroom

- Large double bed with drawers below (option of scissor berths)
- Wardrobe with full length mirror
- Deck hatch
- Storage lockers
- LED overhead (24v)
- Window with opening portlights
- Manual tension venetian blinds
- 220/240v outlets (1)
- USB charging points (2)
- Fitted carpets

En-suite bathroom

- Solid surface worktops
- Wash basin with Monobloc mixer tap
- Separate stall shower with extractor fan and automatic pump out
- Mirror
- LED overhead and concealed lighting (24v)
- Storage locker

- Window with opening portlight
- Manual tension venetian blinds
- Solid surface flooring
- Bathroom accessories
- 220/240v shaver socket

Power and drive systems

- Twin Volvo IPS engines (driving contra rotating propellers via pod drive)
- Power-assisted steering (electrical)
- Electronic engine controls
- Joystick manoeuvring system
- Volvo active corrosion protection system for pod drive
- Engine room extractor fans with electronic time delay
- Volvo interceptor trim system integrated into Volvo engine system (integrated into Volvo/Garmin display)
- Engine room lighting
- Access from cockpit hatch
- Fresh water supply point in engine room
- Engine room insulation
- High volume air intakes
- Engine beds integrally moulded with hull for

strength and vibration absorption

- Bulkheads integrally bonded
- Engines flexibly mounted
- Automatic fire extinguisher with remote override
- Automatic/manual bilge pumps
- 24v to 12v converters for certain navigation and radio circuits

Electrical systems

24 Volt:

- 4 x heavy-duty batteries for engine starting
- 4 x heavy-duty auxiliary batteries
- Engine alternators charge via split charge relays to isolate engine start batteries from auxiliaries and ensure efficient charging of both battery banks
- 40-amp 24v float battery charger
- Battery paralleling system (for engine start back-up)
- Remote battery master switches with control switch at main panel
- Circuit breakers on all circuits
- Galvanic isolation system
- Princess Connect telemetry and maintenance

220/240 Volt:

- Shore support inlet (32A)
- Power points in owner's stateroom, forward guest cabin, galley, lower and upper saloon
- Polarity check system
- Earth leakage safety trip
- Shaver points in both bathrooms
- 4kW generator
- 12v battery charger

Fuel system

- Twin fuel tanks (in NS8 marine grade alloy) with interconnection system
- Fuel fillers on both side decks
- High-capacity duplex fuel filters with water traps with change-over valves, water contamination warning integrated into Volvo/Garmin display (integrated into Volvo/Garmin display)
- Remote fuel cocks in cockpit seat locker for main engines and generator
- Fuel gauges integrated into Volvo/Garmin display

Water system

- Water capacity totalling 80 gal / 96 US gal / 364 l plus 11 gal /13 US gal / 50 l hot water calorifier
- Water heated by engine and 240v immersion heater
- Automatic water pump with filter
- Pump main circuit breaker at AC/DC switch panel
- Water level gauge
- Deck filler
- Electric quiet flush freshwater toilet system with holding tank, content gauge and low noise manual overboard discharge, as well as dockside discharge

Fire extinguishers

- Automatic fire extinguisher in engine room and generator space
- Hand-operated fire extinguishers (4) in: owner's stateroom, forward guest cabin, galley and upper saloon

Bilge pumps

- Automatic electric bilge pumps with manual override (3 in all)

- High-capacity manual bilge pump in cockpit seat locker with valve system and suction points in engine room and accommodation space
- Electric bilge pumps to have controls, warning lights with audible alarm and "pump out" isolation at helm

Other standard equipment

- Fenders (6)
- Mooring warps (4)
- First aid kit
- Boat hook
- Fitted bed covers for both cabins
- Tool kit
- Owner's manual and engine manual
- Anchor winch backup handle
- Ensign staff
- Ships document case

Finishes

- Furniture in Rovere oak with satin finish as standard. Optional finishes include ash or silver oak with a satin finish or walnut wood in a satin or gloss finish

- Galley and bathroom worktops in solid surface
- Timber-laid galley, saloon and helm floors
- Bathroom floors in solid surface
- Manual tension venetian blinds to all windows and portholes, curtains to saloon doors
- Choice of high-quality carpets and upholstery fabrics from extensive range

V50 Open

Layout and Specifications



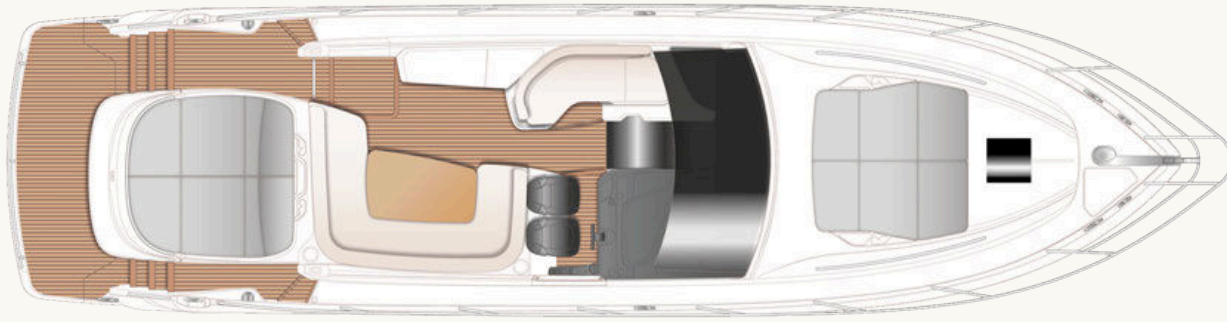

V50 Main Deck



V50 Lower Deck

Principal Dimensions

Length overall (incl. pulpit)	52 ft 7 in / 16.02m
Length overall (excl. pulpit)	50 ft 4 in / 15.35m
Beam	13 ft 4 in / 4.08m
Draft	3 ft 8 in / 1.11m
Displacement approx.	17,781 kg / 39,200 lbs*
Fuel capacity	341 gal / 410 US gal / 1,550 l
Water capacity (excl. calorifier)	76 gal / 91 US gal / 345 l
Black water tank	37 gal / 44 US gal / 170 l

Engines - Diesel

Twin Volvo IPS 650 (2 x 480mhp) Maximum speed range - 28-30 knots[†]

Full Specification

Deck fittings

- 6mm teak-laid transom platform, cockpit deck and steps to side deck
- Lewmar Reversible electric anchor winch with foredeck and helm position controls
- Self-stowing anchor system incorporating one 20kg/44lb Lewmar Delta galvanised steel anchor with flush pin shackle fitted and 40m galvanised 9.5mm chain
- Stemhead roller with automatic anchor launch and retrieve
- Stainless-steel bow, stern and spring cleats
- Stainless-steel bow fairleads
- Stainless-steel pulpit and guardrails
- Stainless-steel coach roof handrails
- PVC rubbing band with stainless-steel insert
- Illuminated crown logo to transom
- Full set of IMCO navigation lights
- Riding light
- Remote control searchlight
- Single electric horn
- Fuel and water fillers

- Holding tank dockside discharge connection
- Deck hatch access to chain locker with fender stowage rack
- Foredeck escape hatch
- Foredeck drinks holders (4)
- Ensign socket

Cockpit and bathing platform

- Self-draining
- Upholstered U-shaped seating/dining area
- Fixed teak dining table
- LED overhead (dimmable) and deck level lighting
- Cockpit cover
- Stainless-steel handrails
- Wet bar with sink, storage, refrigerated coolbox
- Lockable access hatch to engine room
- 220/240v shore support inlet in locker
- Life raft stowage locker
- Transom platform with integrated swimming ladder (with electro-hydraulic raise/lower mechanism)

- Transom steps to access stern from bathing platform when in lowered position
- Aft sunbed with drinks holders (4)
- Tender garage with electro-hydraulic door and electric winch for tender up to 3.25m
- Transom door leading to bathing platform
- New style hot and cold transom shower
- Storage lockers
- Waterproof speakers linked to saloon Fusion Apollo MS-RA670 sound system
- Fender stowage rack in engine room/lazarette
- Cockpit locker containing remote fuel cocks, manual bilge pump with valve chest and manual controls for automatic fire extinguisher

Helm

- Twin upholstered seats, manually adjustable helm seat (fore/aft) with sit/stand facility, fixed position navigator seat
- J-shaped companionway seating with drinks holders (2)
- Instrument console incorporating engine

- instruments and fuel gauges
- Instruments and controls at helm position include:
 - Power-assisted steering
 - Adjustable steering wheel
 - High speed magnetic compass
 - Electronic engine controls with integrated trim control
 - Joystick manoeuvring control
 - Electric anchor winch with remote control
 - Volvo/Garmin 16" MFD, incorporating GPS chart plotter, engine instrumentation, alarm warning system, autopilot control, fuel gauges, speed and distance log, echo sounder & steering angle indicator
 - VHF with DSC R/T with intercom
 - Single remote-control searchlight
 - Horn button to operate single electric horn
- Twin windscreen wipers
- Windscreen freshwater pressure wash
- Bilge pump controls with audible and visual alarm for bilge pumps (3)
- Electric drop window to starboard side
- Engine room fire extinguisher warning system
- Drinks holder (2) at console, with additional drink holder (1) at base of navigator seat

- Toughened un-tinted glass screen
- Black mesh sunscreens for exterior use
- USB charging points
- Riding light, helm and nav light control switches
- 6mm teak-laid flooring
- Power-assisted steering
- Adjustable steering wheel
- High speed magnetic compass
- Electronic engine controls with integrated trim control
- Joystick manoeuvring control
- Electric anchor winch with remote control
- Volvo/Garmin 16" MFD, incorporating GPS chart plotter, engine instrumentation, alarm warning system, autopilot control, fuel gauges, speed and distance log, echo sounder & steering angle indicator
- VHF with DSC R/T with intercom
- Single remote-control searchlight
- Horn button to operate single electric horn

Lower saloon

- U-shaped sofa with single drawer and top loading storage (top loading storage is occupied by A/C unit when option is specified)

- Table
- Storage lockers
- LED overhead downlighters
- 24/240v main electrical control panel with battery isolation switches
- Skylight
- Fusion Apollo MS-RA670 audio unit (with external USB connection) with Fusion 6" CL602 (2) speakers
- Window with opening portlight (1)
- Manual tension venetian blinds
- Thermal heat alarm
- 220/240v outlets (1)
- USB charging points (2)

Galley

- White Solid Surface worktop
- 2 zone ceramic hob
- White Solid Surface sink with Monobloc mixer tap (sink remains White Solid Surface for all options)
- Combination microwave/convection oven with grill
- Full height 270lt fridge/freezer
- Waste bin

- High/low storage cupboards, drawers and lockers
- Timber-laid flooring
- Under floor storage bin
- Window with opening portlight
- Manual tension venetian blind
- Hob extractor fan
- Cutlery and crockery storage
- Chopping board
- 220/240v power outlets (4)
- LED overhead task lighting (24v), concealed light and night lighting
- Storage bin under galley sole

Accommodation

- All cabins and bathrooms feature opening portholes
- All cabins feature 220/240v power points
- All bathrooms feature electric freshwater toilets and 240v shaver points

Owner's stateroom

- Large double bed with bedside tables drawers below

- Wardrobe with shelves and full-length mirror
- Drawers and storage lockers
- Sideboard
- LED overhead and individual berth lights (24v)
- Starboard side sofa
- Panoramic windows in toughened glass with opening ports
- Manual tension venetian blinds
- Fitted carpet
- 220/240v outlets (2)
- USB charging points (4)

En-suite bathroom

- Solid Surface worktop
- Wash basin with Monobloc mixer tap
- Separate stall shower with extractor fan and auto pump out
- Mirror
- LED overhead and concealed lighting (24v)
- Storage locker
- Windows with opening portlight
- Manual tension venetian blind
- Solid Surface flooring
- Bathroom accessories
- 220/240v shaver socket

Forward stateroom

- Large double bed with drawers below (option of scissor berths)
- Wardrobe with full length mirror
- Deck hatch
- Storage lockers
- LED overhead (24v)
- Window with opening portlights
- Manual tension venetian blinds
- 220/240v outlets (1)
- USB charging points (2)
- Fitted carpets

En-suite bathroom

- Solid Surface worktop
- Wash basin with Monobloc mixer tap
- Separate stall shower with extractor fan and automatic pump out
- Mirror
- LED overhead and concealed lighting (24v)
- Storage locker
- Window with opening portlight
- Manual tension venetian blinds
- Solid Surface flooring

- Bathroom accessories
- 220/240v shaver socket

Power and drive systems

- Twin Volvo IPS engines (driving contra rotating propellers via pod drive)
- Power-assisted steering (electrical)
- Electronic engine controls
- Joystick manoeuvring system
- Volvo active corrosion protection system for pod drive
- Engine room extractor fans with electronic time delay
- Volvo interceptor trim system integrated into Volvo engine system (integrated into Volvo/Garmin display)
- Engine room lighting
- Access from cockpit hatch
- Fresh water supply point in engine room
- High volume air intakes
- Engine beds integrally moulded with hull for strength and vibration absorption
- Bulkheads integrally bonded
- Engines flexibly mounted
- Automatic fire extinguisher with remote override

- Automatic/manual bilge pumps

Electrical systems

24 Volt:

- 4 x heavy-duty batteries for engine starting
- 4 x heavy-duty auxiliary batteries
- Engine alternators charge via split charge relays to isolate engine start batteries from auxiliaries and ensure efficient charging of both battery banks.
- 40-amp 24v float battery charger
- Battery paralleling system (for engine start back-up)
- Remote battery master switches with control switch at main panel
- Circuit breakers on all circuits
- Galvanic isolation system
- 12v voltage dropper for certain navigation and radio circuits
- Princess Connect telemetry and maintenance system

220/240 Volt:

- Automatic fire extinguisher situated by generator
- Shore support inlet (32A)
- Power points in owner's stateroom, forward guest cabin, galley and lower saloon
- Generator/ shore support change-over switch
- Polarity check system
- Earth leakage safety trip
- Shaver points in both bathrooms
- 4kW generator
- 12v battery charger

Fuel system

- Twin fuel tanks (in NS8 marine grade alloy) with interconnection system
- Fuel fillers on both side decks
- High-capacity duplex fuel filters with water traps with change-over valves, water contamination warning integrated into Volvo/Garmin display (integrated into Volvo/Garmin display)
- Remote fuel cocks in cockpit locker for main engines and generator
- Fuel gauges integrated into Volvo/Garmin display

WATER SYSTEM

- Water capacity totalling 80 gal / 96 US gal / 364 l plus 11 gal / 13 US gal / 50 l hot water calorifier
- Water heated by engine and 240v immersion heater
- Automatic water pump with filter
- Pump main circuit breaker at AC/DC switch panel
- Water level gauge
- Deck filler
- Electric quiet flush freshwater WC system with holding tank, content gauge and low noise manual overboard discharge, as well as dockside discharge

Fire extinguishers

- Automatic fire extinguisher in engine room and generator space
- Hand-operated fire extinguishers (4) in: owner's stateroom, forward guest cabin, galley & upper saloon

Bilge pumps

- Automatic electric bilge pumps with manual override (3 in all)
- High-capacity manual bilge pump in cockpit locker with valve system and suction points in engine room and accommodation space
- Electric bilge pumps to have controls, warning lights with audible alarm and "pump out" isolation at helm

Other standard equipment

- Fenders (6)
- Mooring warps (4)
- Ensign staff
- First aid kit
- Boathook
- Functional fitted bed covers as standard for both cabins
- Tool kit
- Owner's manual and engine manual
- Anchor winch backup handle
- Ships document case

Finishes

- Furniture finished in a choice of Rovere Oak and

Alba Oak in satin finish as standard. Silver Oak or Walnut in satin or gloss finish available as an option

- Galley countertops in Solid Surface
- Galley units and under stair storage in matte Taupe Grey HPL
- Timber-laid floors to galley, saloon & helm
- Bathroom vanity tops in Solid Surface
- Bathroom floors in Solid Surface
- Venetian blinds to all windows and portholes
- Choice of high-quality carpets and upholstery from extensive range



V40



The V40 quintessentially showcases the sleek exterior, performance and exceptional seakeeping of the Princess V Class range. Her port light windows cascade across the length of her deep-V hull, flooding the saloon and cabins with natural light. When entertaining, her spacious cockpit provides the perfect setting with the option to specify a convertible sunbed aft.





Below deck, her interior design depicts the modern V Class look throughout. Her spacious saloon and well equipped galley combine for a highly sociable entertaining space, while both cabins exude contemporary style and generous proportions. The forward cabin has an en-suite bathroom with secondary access to the saloon whilst the aft cabin can be fitted with optional sliding berths to provide easy conversion to a double bed when required.





Experience the V40



Take a virtual tour of the V40



V40

Layout and Specifications



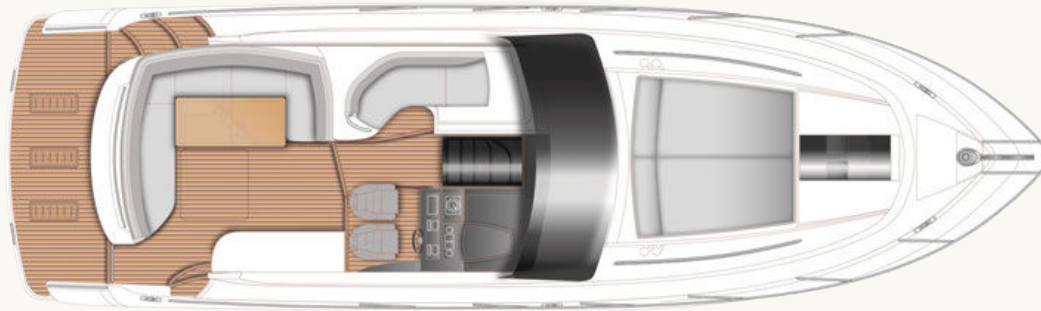

V40 Main Deck

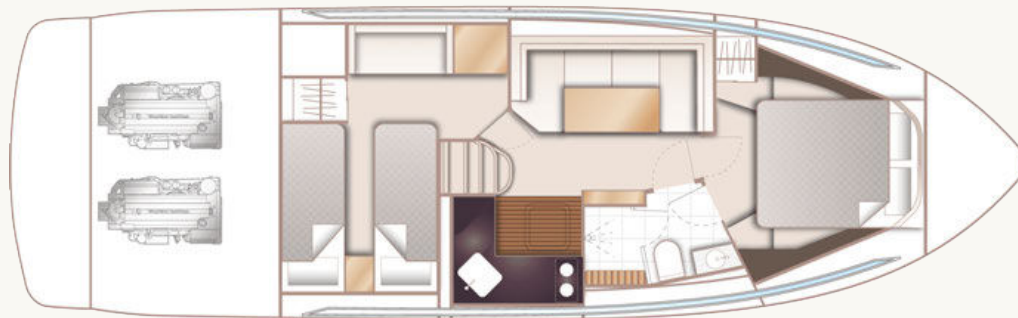

V40 Lower Deck

Principal Dimensions

Length overall (incl. pulpit)	42 ft 6 in / 12.98m
Length overall (excl. pulpit)	40 ft 6 in / 12.35m
Beam	12 ft 5 in / 3.81m
Draft (drives raised)	1 ft 10 in / 0.56m
Draft (drives lowered)	3 ft 4 in / 1.02m
Displacement approx.	9,592 kg / 21,147 lbs*
Fuel capacity	161 gal / 193 US gal / 730 l
Water capacity (excl. calorifier)	63 gal / 76 US gal / 288 l
Black water tank	19 gal / 22 US gal / 85 l

Engines - Diesel

Twin Volvo D6-340 DP (2 x 340mhp)	Maximum speed range - 34-36 knots [†]
-----------------------------------	--

Full Specification

Deck fittings

- Teak laid transom platform, cockpit deck and steps to side decks
- Reversible electric anchor winch with helm position controls
- Self-stowing (16 kg/35 lbs) Delta anchor with 30m of chain
- Stemhead roller with automatic anchor launch and retrieve
- Chain locker with stowage for 4 fenders (stowage for an additional 2 fenders in engine room)
- Stainless steel bow, stern and spring cleats
- Bow fairleads
- Stainless steel pulpit and guardrails
- Foredeck hatch with integrated skylight
- Rubbing band with stainless steel insert
- Full set of IMCO navigation lights
- Riding light
- Remote control searchlight
- Twin electric horns
- Fuel and water fillers

Cockpit

- Self draining
- L-shaped seat opposite helm position
- U-shaped seating/dining area
- Teak table (with optional conversion to double sunbed)
- Cockpit lighting
- Audio unit linked to saloon with local control, paired with Fusion 6" FR-602 speakers (2)
- Sliding sun roof (electrically operated) within fixed GRP structure and integrated radar arch
- Aft tonneau canvas cover
- Stainless steel grabrails
- Wetbar with sink, top loading cool box and optional electric barbecue
- Locker with remote fuel cocks
- 220/240v shore support inlet
- Life raft storage locker
- Engine access hatch with gas strut support and storage for 2 fenders
- Transom gate leading to integral bathing platform

- Teak laid bath platform with retractable swimming ladder (manual), hot and cold transom shower, and space for tender
- Large transom storage locker with access via transom doors and hatch in stern seat (will accept deflated dinghy and outboard engine)

Helm position

- Double helm seat with sit/stand facility
- Instrument console incorporating engine instruments and fuel gauges
- Instruments and controls at helm position:
 - Power-assisted electro-hydraulic steering
 - Adjustable steering wheel
 - Electric anchor winch remote control
 - Trim tab controls with indicators
 - Sterndrive trim controls
 - VHF with DSC R/T
 - Speed and distance log (with sea temperature)
 - Echo sounder with alarm
 - Remote control searchlight
 - High-speed compass

- Horn button
- Chart table
- Windscreen wipers (2 speed)
- Freshwater windscreen wash
- Bilge pump controls with visual 'pump running' warnings

Saloon

- U-shaped sofa, converting to double berth with built in stowage for infill cushions
- Dining table
- Cocktail cabinet
- Cupboards and lockers
- Fusion Apollo RA-670 audio unit with WiFi and Bluetooth connected to saloon Fusion 6" CL602 speakers and cockpit speakers (2)
- Window with opening porthole
- Manual tension venetian blind
- LED overhead and concealed lighting (12v)
- Access stairway to lower accommodation
- Fitted carpet

Galley

- Solid surface worktop

- 2-zone gas hob with flame-failure device
- Combination microwave/conventional oven with grill
- Stainless steel sink with mixer tap
- Chopping board
- Waste bin
- Drawers and storage cupboards
- Refrigerator with freezer compartment
- Window with opening porthole
- Manual tension venetian blind
- LED overhead and task lighting (12v)
- 220/240v outlets (4)
- Timber flooring

Accommodation

- All cabins and bathrooms feature opening portholes
- All cabins feature 220/240v power points
- All bathrooms feature electric freshwater toilets and 240v shaver points

Owner's cabin

- Large double bed with drawers below
- Wardrobe with shelves

- Dressing table
- Mirror
- Storage lockers and drawers
- Window with opening porthole
- Manual tension venetian blind
- Deck hatch with integrated skylight and blind
- LED overhead and concealed lighting (12v)
- Individual berth lights
- 220/240v outlets (2)
- Fitted carpet

En-suite bathroom

- Wash basin with solid surface worktop
- Mirror
- Storage lockers
- Shower compartment with automatic pump out
- Window with opening porthole
- Manual tension venetian blind
- LED overhead and concealed lighting (12v)
- Bathroom accessories
- Solid surface flooring

Guest cabin

- Two single berths

- Wardrobe with shelves
- Mirror
- Storage lockers
- Panoramic with opening porthole
- Manual tension venetian blind
- LED overhead and concealed lighting (12v)
- Individual berth lights
- 220/240v outlets (2)
- Fitted carpet

Gas

- Overboard vented and drained locker for 2 gas bottles
- Copper gas line sheathed in PVC
- Gas regulator
- Gas low/system test meter

Power and drive systems

- Twin duo-prop stern drives
- Engine room lighting
- Engine room access hatch and ladder
- Power-assisted electro-hydraulic steering system
- Trim tabs with indicators
- Electronic engine and gear shift controls

- Engine room extraction

Electrical systems

12 Volt:

- 2 x heavy duty batteries for engine starting
- 2 x heavy duty auxiliary batteries
- Battery link facility with remote control at helm position
- Both battery banks are charged using a voltage sensitive relay that parallels both battery banks when a charging source is present
- 75-amp 12v float battery charger
- Remote battery master switches with control switch at main switch panel
- Circuit breakers on all circuits
- 12v voltage dropper for certain navigation and radio circuits
- Princess Connect telemetry and maintenance system

220/240 Volt:

- Automatic fire extinguisher
- 30-amp shore support inlet

- Polarity check system
- Earth leakage safety trip
- Circuit breakers on all circuits
- Power points in: owner's cabin, guest cabin, galley and saloon area
- Shaver point in bathroom

Fuel system

- Twin fuel tanks (in NS8 marine grade alloy) with interconnection system giving 160 gal / 192 US gal / 730l capacity
- Fuel fillers on port and starboard side decks
- Volvo fuel filter/ water separator (one per engine) with water warning sensors connected to warning lights at helm position
- Remote fuel cocks in cockpit locker
- Fuel gauges at main helm console

Water system

- Water tanks totalling 64 gal / 77 US gal / 290l plus 7 gal / 8.5 US gal / 32l hot water calorifier
- Water heated by engines and 240v immersion heater
- Automatic water pump with filter

- Main circuit breaker at switch panel
- Water level gauge
- Deck filler

Fire extinguishers

- Automatic/manual override fire extinguishers in engine room with warning system at helm position
- Hand-operated fire extinguishers (4) in owner's cabin, guest cabin, galley and helm position

Bilge pumps

- Automatic/manual override electric bilge pumps in engine room (2), rudder area, lazarette and forward accommodation (6 in all)
- High-capacity manual bilge pump with valve system and suction points in same areas
- Electric bilge pumps have controls and warning lights at main helm and warning light with audible alarm at flybridge helm

Other standard equipment

- Ensign staff

- Fenders (6)
- Mooring warps (4)
- Boat hook
- First-aid kit
- Tool kit
- Owner's manual and engine manual
- Quilted bedspreads supplied to both cabins
- Ship's document case
- Anchor winch back up handle

Finishes

- Teak-laid decks to transom platform, cockpit deck and steps to side decks
- Timber-laid floor to galley area
- Furniture in Rovere oak with satin finish as standard. Optional finishes include ash or silver oak with a satin finish or walnut wood in a satin or gloss finish
- Tiled floor in bathroom suite in guest accommodation
- Solid surface wash basin counter tops in bathroom suite in guest accommodation
- Galley worktop in solid surface finish
- Choice of high-quality carpet and upholstery fabric from extensive range

- Blinds or sunscreens to all windows and portholes

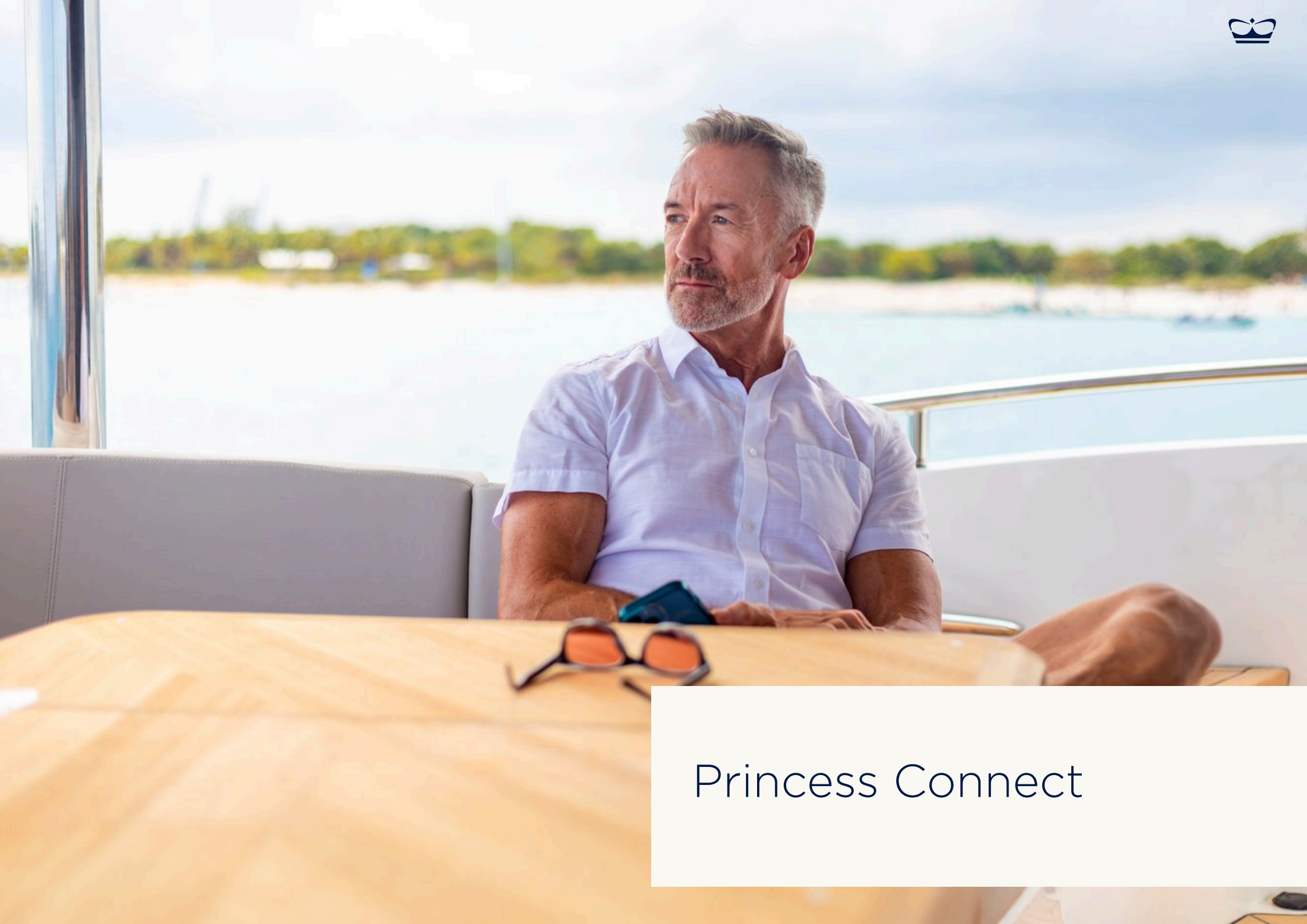

Princess Connect

For your peace of mind, we provide a telemetry and transparent maintenance system as standard on all our new yachts.

Princess Connect is designed to keep you and your yacht in continuous communication, providing remote monitoring anywhere in the world.

In addition to enhanced control onboard, Princess Connect acts as your virtual service operator, providing personalised notifications on upcoming maintenance requirements, a digital library of user guides and manuals, and further support information.





Distributor Information



With an extensive network of distributors around the globe, we are able to bring you personalised world-class service almost anywhere. We do all that we can to make sure that the process of buying a Princess is yet another exciting aspect of ownership.

Our specialist dealers have years of experience and unparalleled knowledge of our yachts. For more information on any one of the yachts in our range, please contact your local Princess office. Address and contact details can be found on our [website](#).

Global Coverage

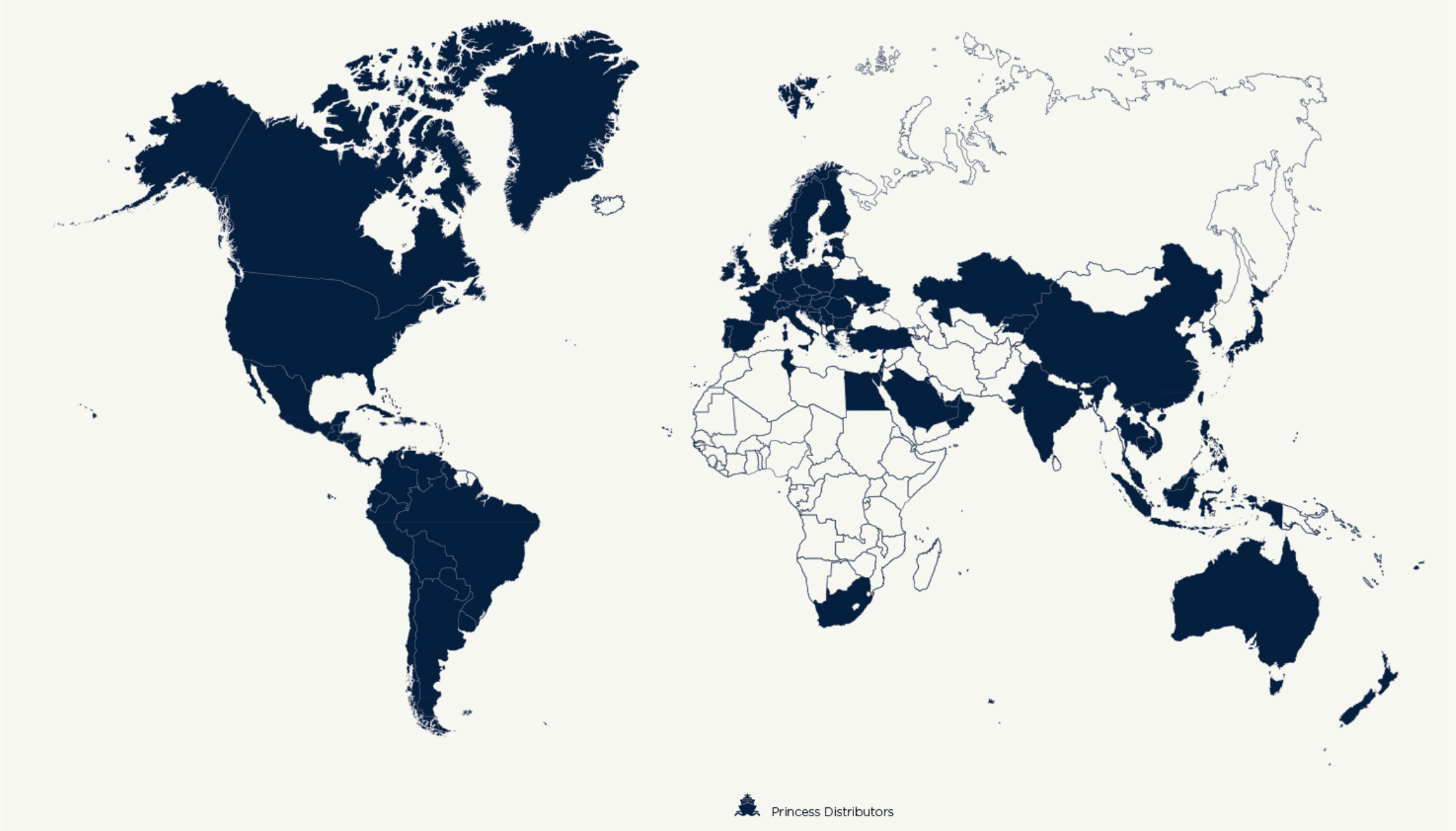



Disclaimer

* Displacements are calculated with 50% fuel and water with liferaft but with no optional equipment fitted or other gear.

† Maximum speeds will vary depending on cleanliness of hull, condition of sterngear, loading of craft, water and air temperatures, sea conditions and other factors. Speed estimates are therefore given in good faith but without warranty or liability on the part of Princess Yachts Limited. Craft illustrated in this brochure may be fitted with certain optional equipment. Specifications may be changed at any time without notice or liability.

‡ Certain specifications, which vary by model, are upgraded on Princess Yachts built for use in North America. Thus, specifications and equipment will vary from the information listed in the brochure for North American Princess Yachts (e.g. air conditioning and an upgraded generator will be included as standard for all North American models and electric cooking facilities will be supplied in place of gas systems). Please contact Princess Yachts America for full details regarding the North American specifications for individual models.



Thank you

For more information or to find a distributor,
please visit our website.